



# Caldern C-Turnier

## 26.-27.08.2017

### Patternübersicht

---

#### Reining

LK 4 #15

LK 3 # 2

LK 1/2 # 1

#### Western Riding

LK 1-3 #7

#### Superhorse

LK 1/2 sen #5



# Caldern C-Turnier

26.-27.08.2017

## Ranch Riding LK 1/2 A #6

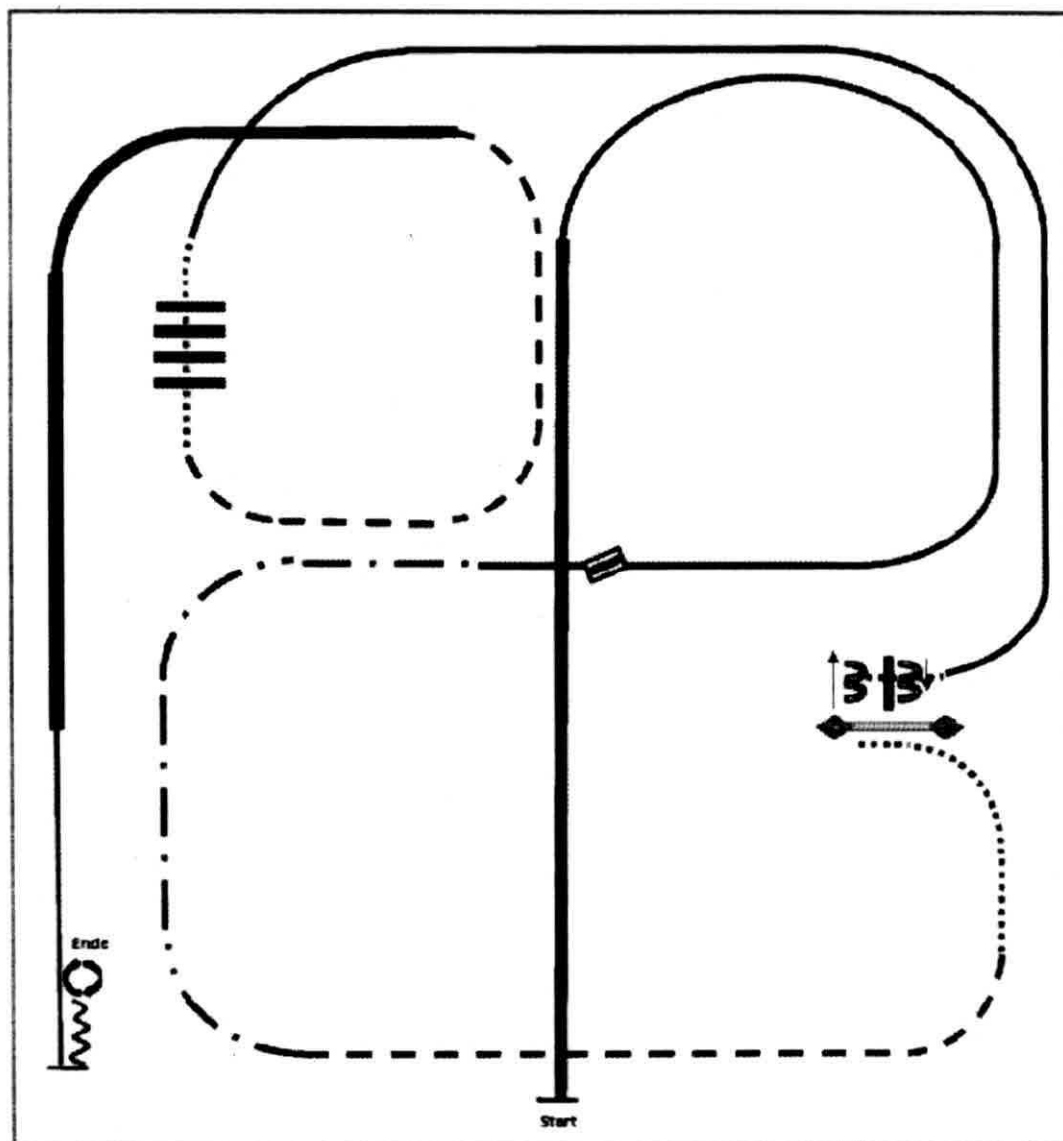

1. Ext. Lope right lead
2. Lope right lead
3. Change leads, Lope left lead
4. Ext. Trot
5. Trot
6. Walk
7. Gate right hand push
8. Sidepass left, right  $\frac{1}{2}$  way
9. Walk over, Lope left lead
10. Walk over
11. Trot
12. Ext. Lope left lead, Lope left lead
13. Stop, Back
14. Turn 360° each direct. (either way 1st)

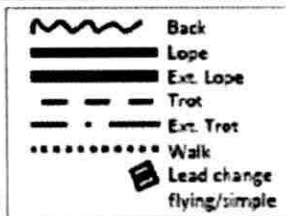



# Caldern C-Turnier 26.-27.08.2017

## Ranch Riding LK 3 RR Pattern 2017 #5

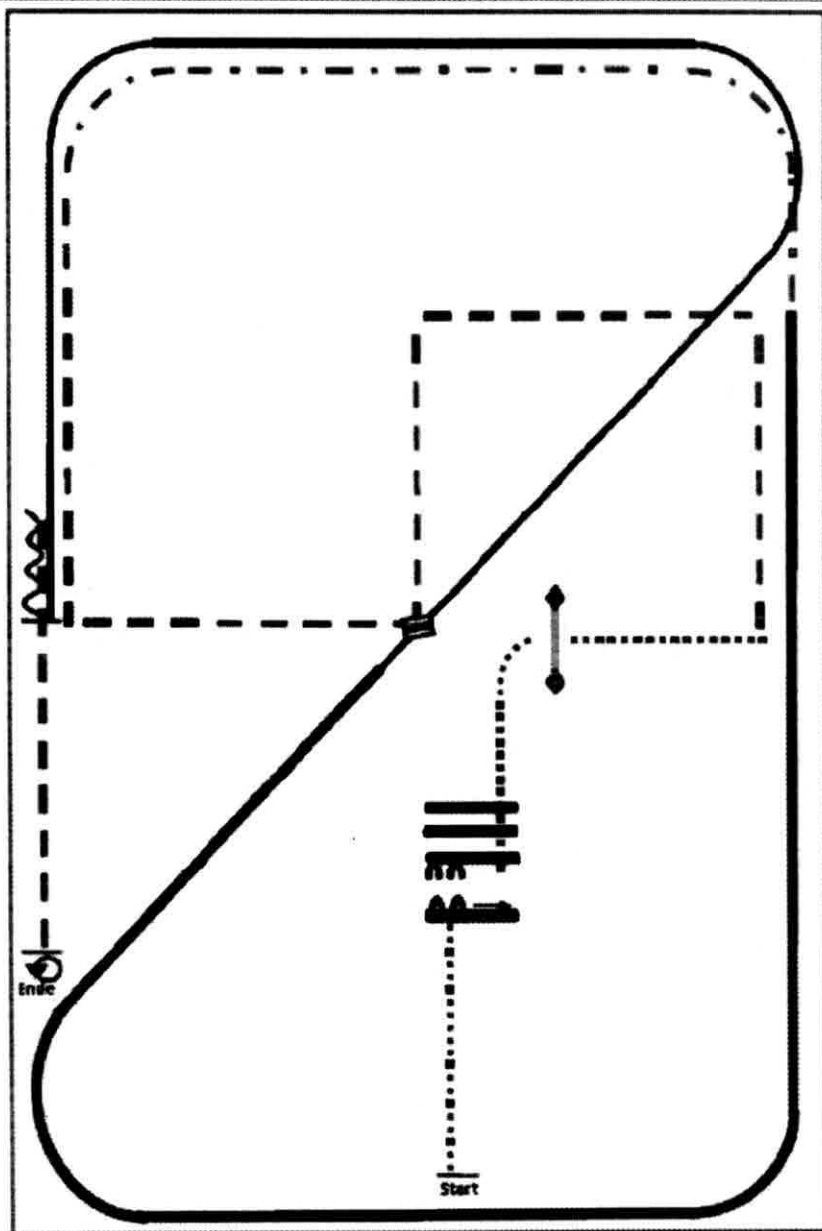

- 1) Walk
- 2) Walk in, sidepass right, walk over.
- 3) Gate, walk.
- 4) Trot corners through the center of the arena.
- 5) Extended trot around the end of the arena.
- 6) Extended lope right lead, lope right lead
- 7) Lead change in the center of the arena.
- 8) Lope left lead.
- 9) Stop, back.
- 10) Trot, stop, 360° turns each direction either way first.





# Caldern C-Turnier

26.-27.08.2017

## Ranch Riding LK 1-3 B Pattern RR 2017 #1

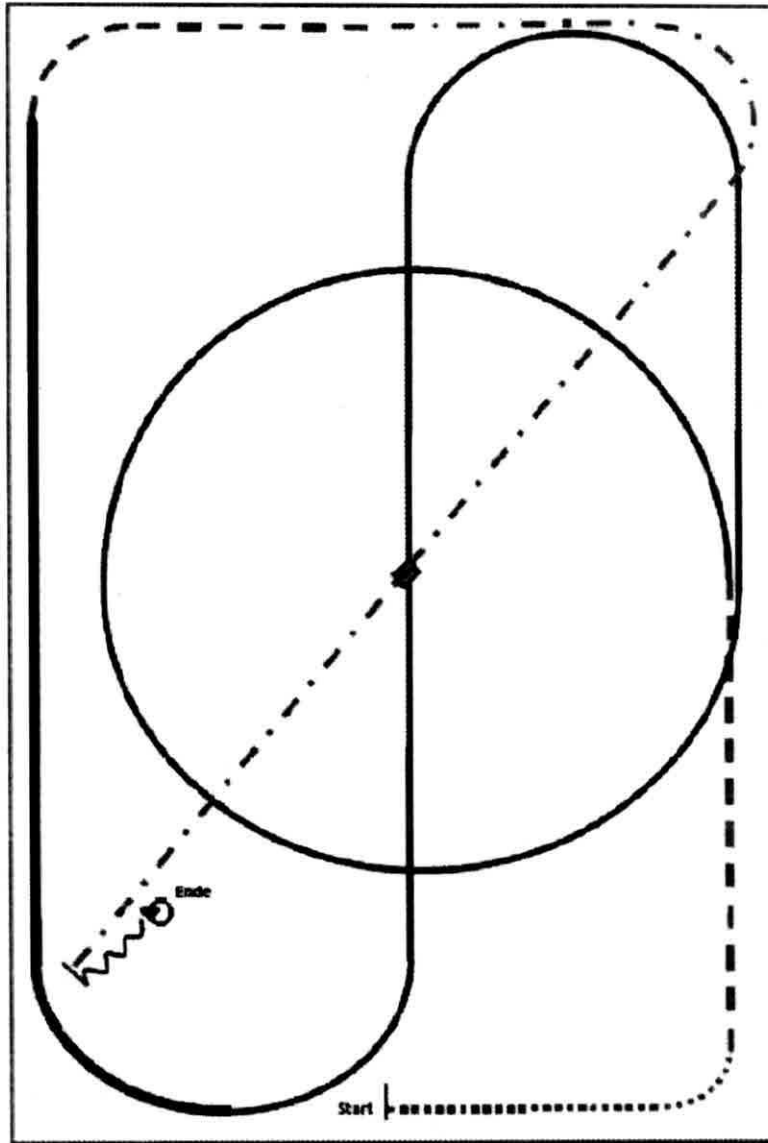

- 1) Walk.
- 2) Trot.
- 3) Lope left lead circle, lope.
- 4) Lead change in the center.
- 5) Lope right lead.
- 6) Extended lope.
- 7) Trot.
- 8) Extended trot.
- 9) Stop, back.
- 10) 360° turns each direction either way first.

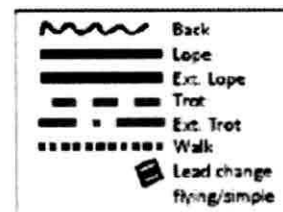



# Caldern C-Turnier 26.-27.08.2017

## Ranch Riding LK 4/5 B Pattern RR 2017 #2

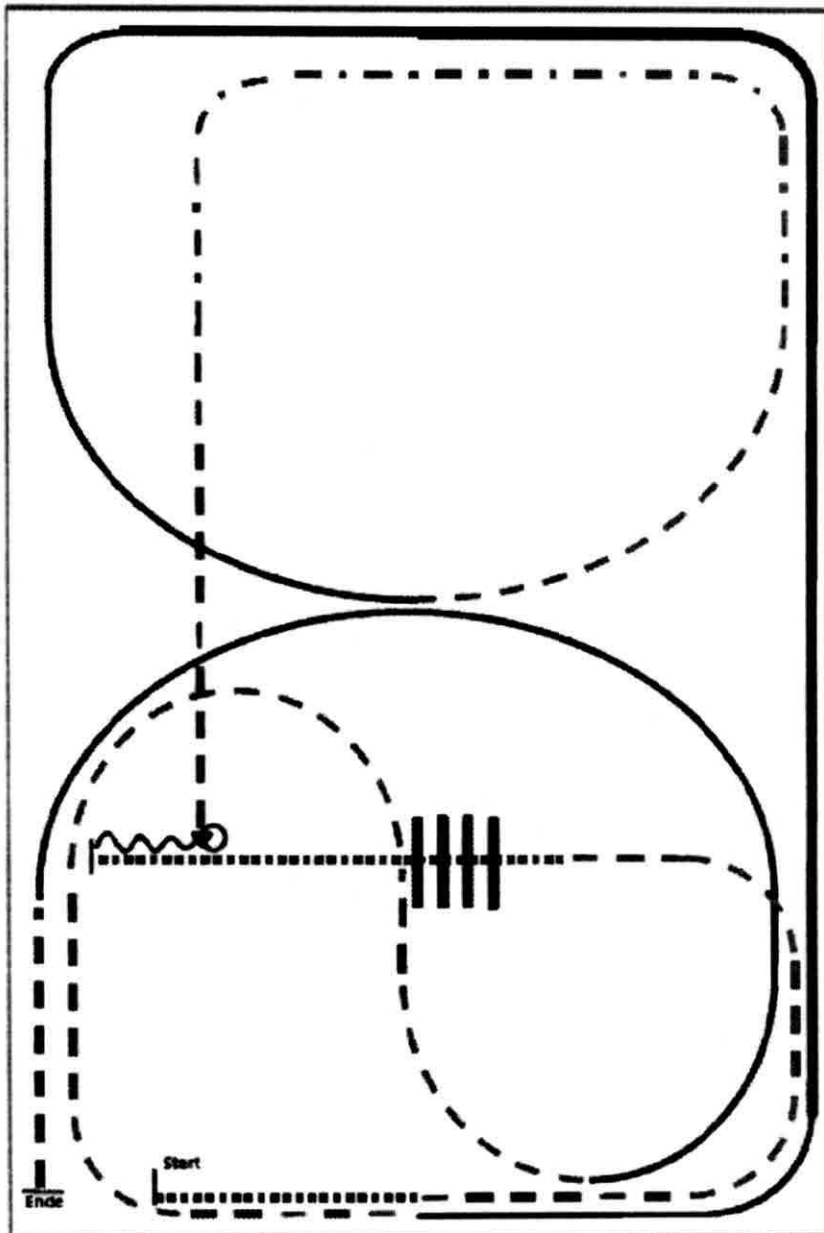

- 1) Walk.
- 2) Trot.
- 3) Walk over, walk.
- 4) Stop, back, 90° turn right.
- 5) Trot, extended trot, trot.
- 6) Lope right lead.
- 7) Extended lope, lope.
- 8) Trot.
- 9) Lope left lead.
- 10) Trot, stop.

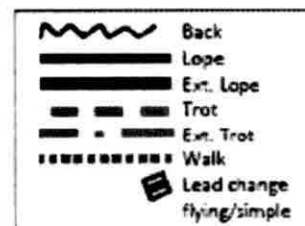



# Caldern C-Turnier 26.-27.08.2017

## Ranch Riding LK 4 A #17

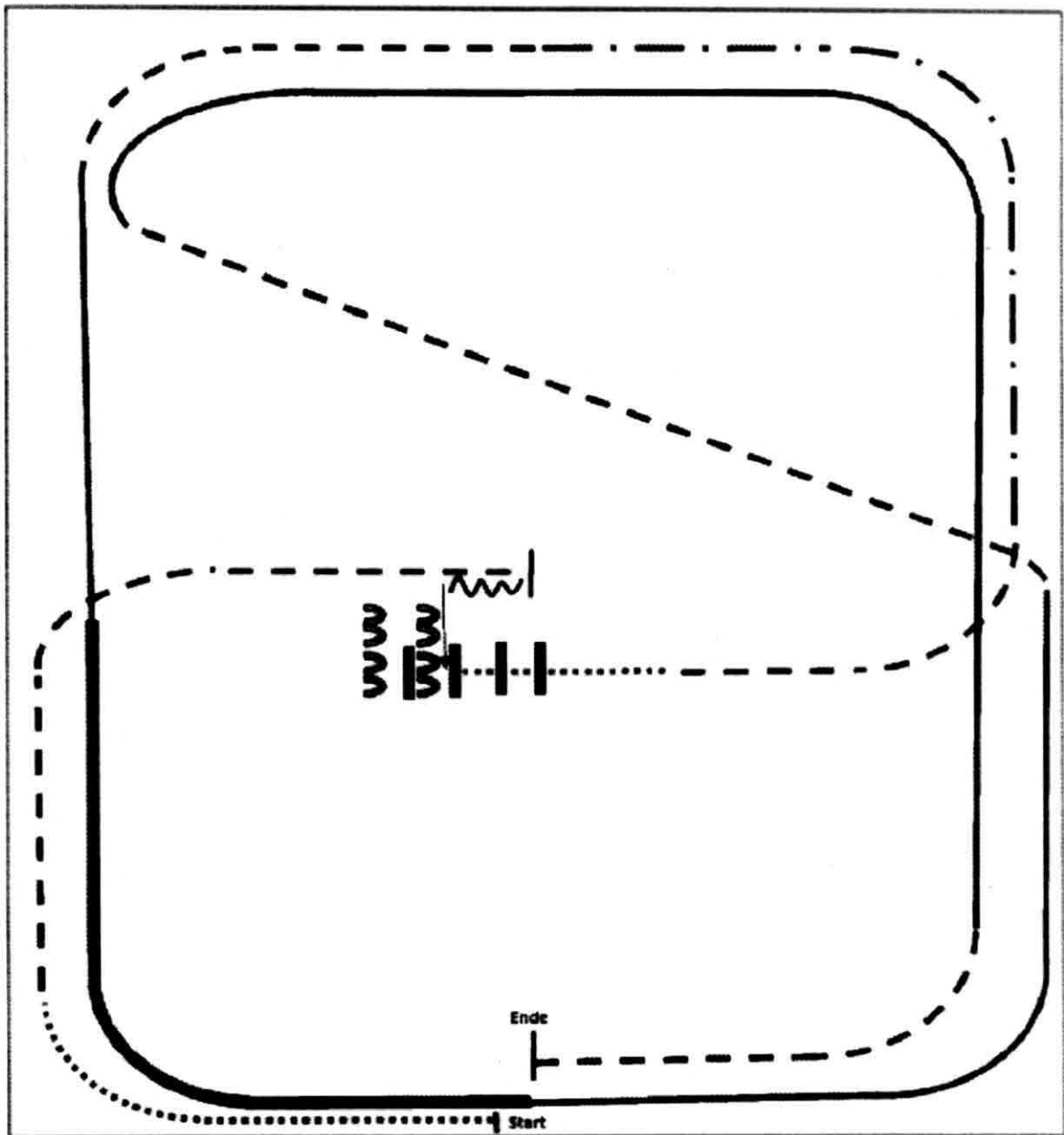

- 1.Walk
- 2.Trot
- 3.Stop, Back
- 4.Sidepass right  $\frac{1}{2}$  way
- 5.Walk over
- 6.Trot
- 7.Ext. Trot, Trot

- 8.Lope left lead
- 9.Ext. Lope left lead
- 10.Lope left lead
- 11.Trot
- 12.Lope right lead
- 13.Jog, Stop

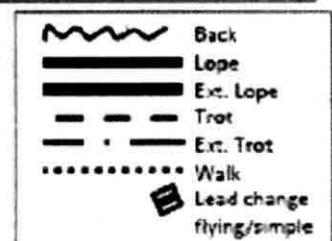



# Caldern C-Turnier

26.-27.08.2017

Showmanship LK 1/2

---

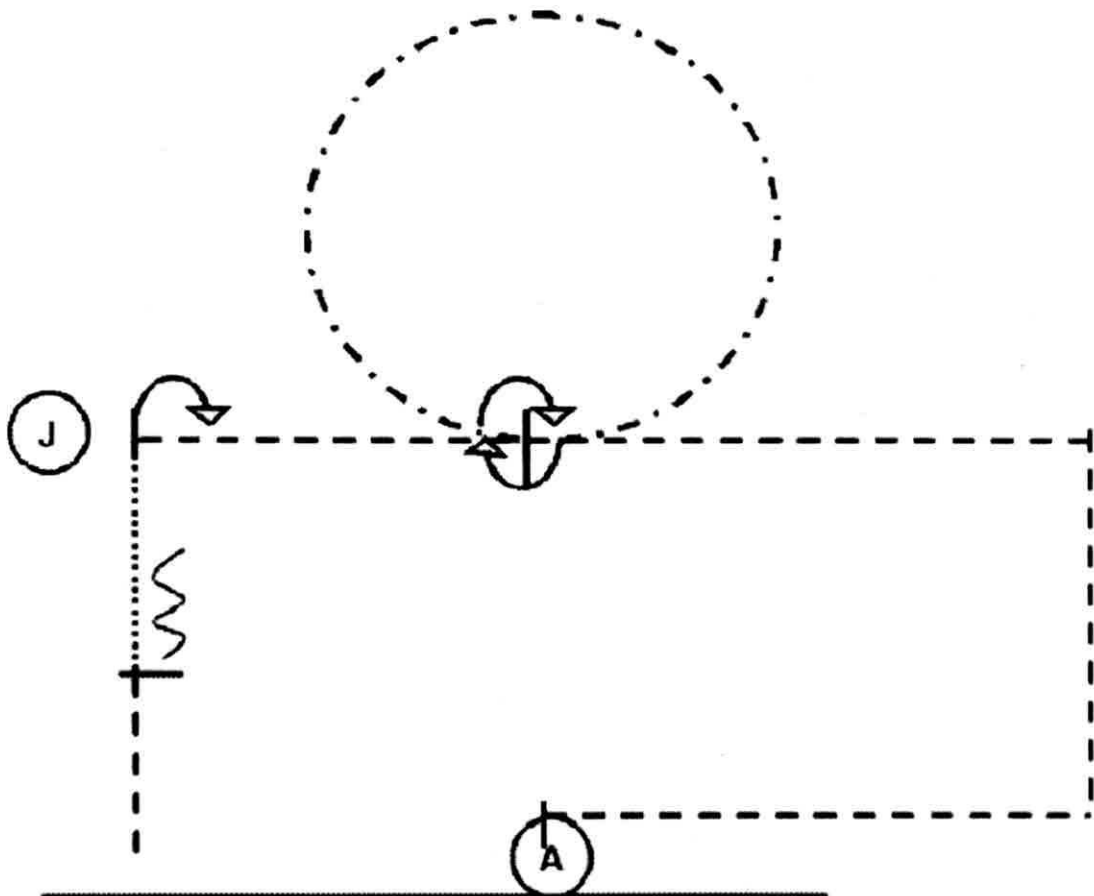

1. Bereithalten bei A, Jog, Jog um die Ecke, Stop,
2. HHW 360°
3. Volte extended Trot, Jog, Stop
4. Set up
5. Walk, Stop, Back up, Jog out



### Showmanship LK 3

---

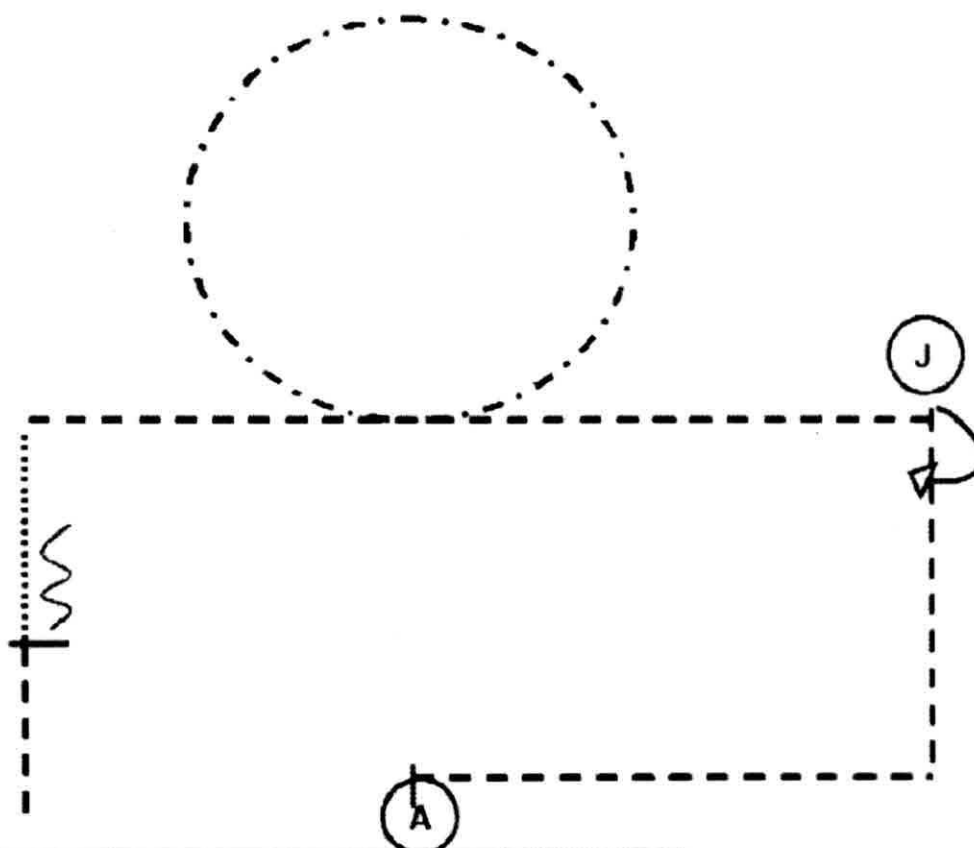

1. Bereithalten bei A, Jog, Jog um die Ecke, Stop,
2. Set up
3. HHW 270°, Jog
4. Extended Jog Volte, Jog
5. Walk, Stop, Back up, Jog out





## Showmanship LK 4/5

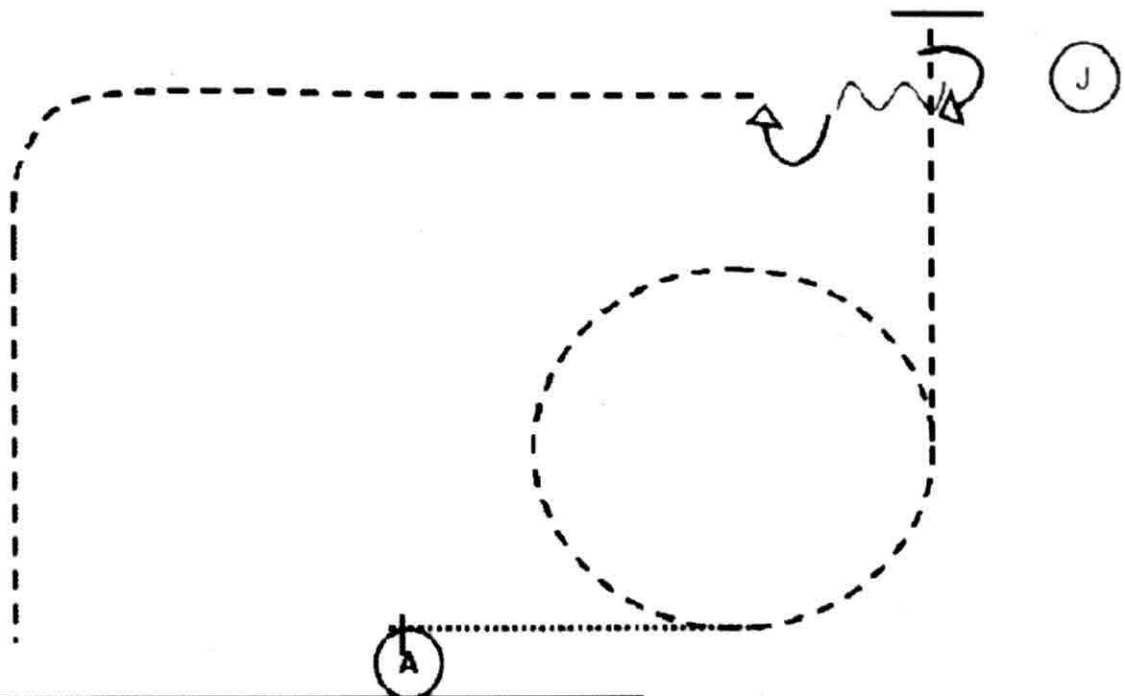

1. Bereithalten bei A, walk
2. Jog, Jogvolte, Stop
3. HHW 90°, Set up
4. Back up, HHW 180°
5. Jog out





# Caldern C-Turnier

## 26.-27.08.2017

### Western Horsemanship LK 1/2 A

---

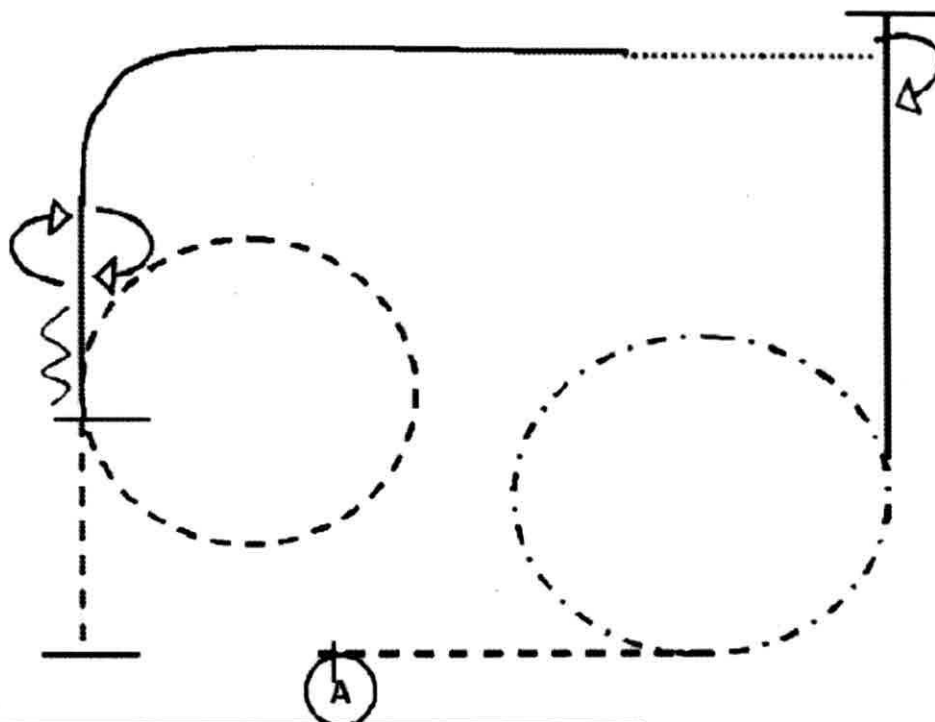

1. Bereithalten bei A, Jog, Extended Jogvolte,
2. Lope left, Stop,
3. 270°HHW rechts, W alk,
4. Lope right, ÜG Jog, Jogvolte
5. Stop, Back up, 360 ° HHW rechts oder links
6. Jog, Stop

	Back
	Lope
	Ext. Lope
	Trot
	Ext. Trot
	Walk
	Lead change flieg./ampfle



# Caldern C-Turnier

26.-27.08.2017

## Western Horsemanship LK 1-3 B

---

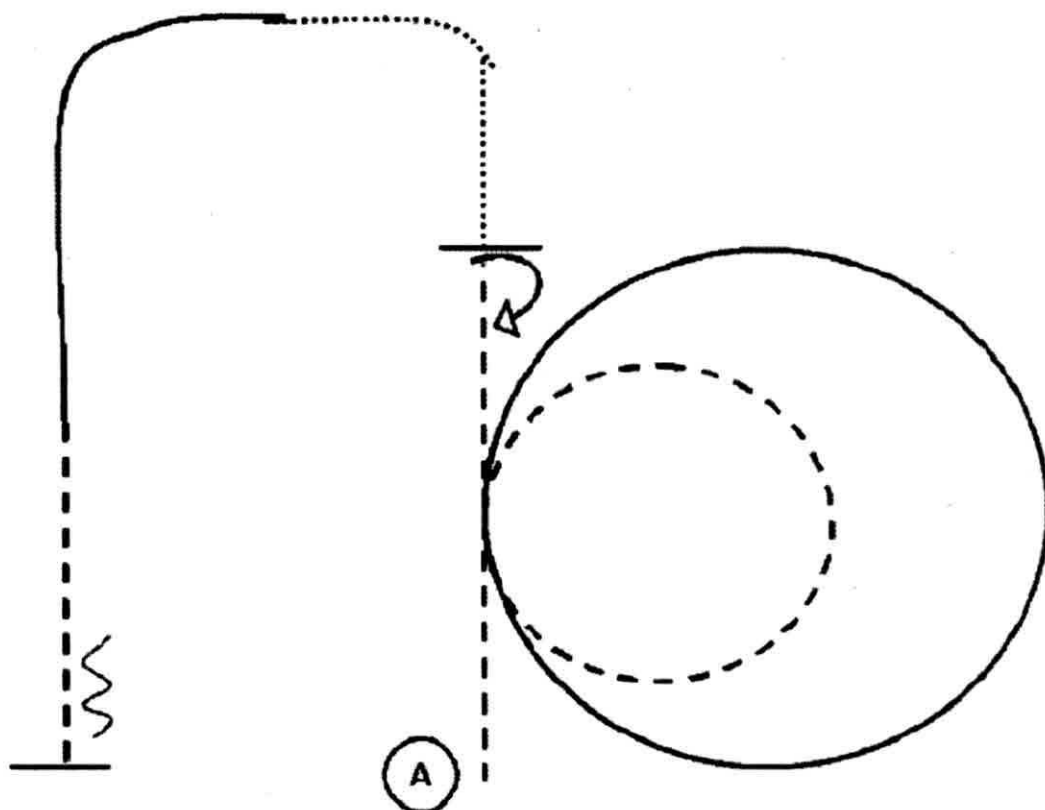

1. Bereithalten bei A, Jog, Jogvolte
2. Lope right, Lopevolte
3. ÜG Jog, Stop
4. HHW 360° rechts oder links
5. Walk, Lope left
6. ÜG Jog, Stop, Back up

	Back
	Lope
	Ext. Lope
	Trot
	Can. Trot
	Walk
	Lead change
	Flying change



# Caldern C-Turnier

## 26.-27.08.2017

### Western Horsemanship LK 3 A

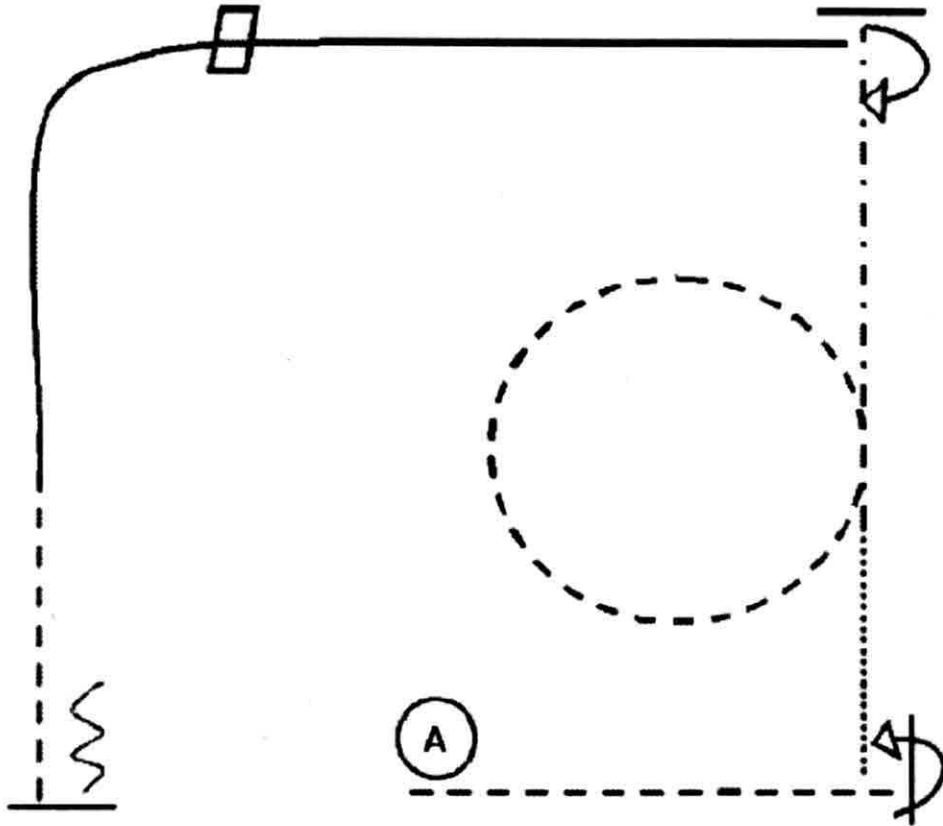

1. Bereithalten bei A, Jog,
2. Stop, 90 ° HHW links, walk
3. Jog, Jogvolte, Extended Jog
4. Stop, 270 ° HHW rechts
5. Lope Right, einfacher o. fliegender Wechsel
6. Lope left, Jog, Stop, Back up

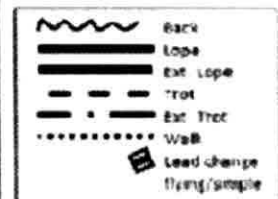

### Western Horsemanship LK 4 A

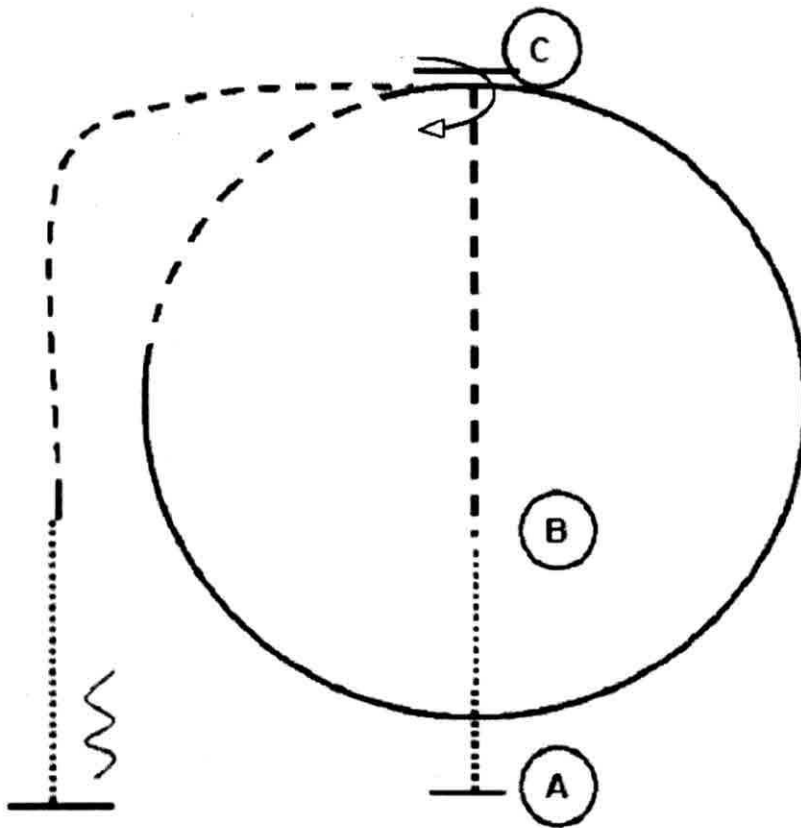

1. Bereithalten bei A, W alk
2. Jog, Stop
3. 270° HHW rechts, Jog,
4. Lope left, Zirkel
5. ÜG Jog, Jog, W alk, Stop, Back up





# Caldern C-Turnier

26.-27.08.2017

Western Horsemanship LK 4/5 B, LK 5 A

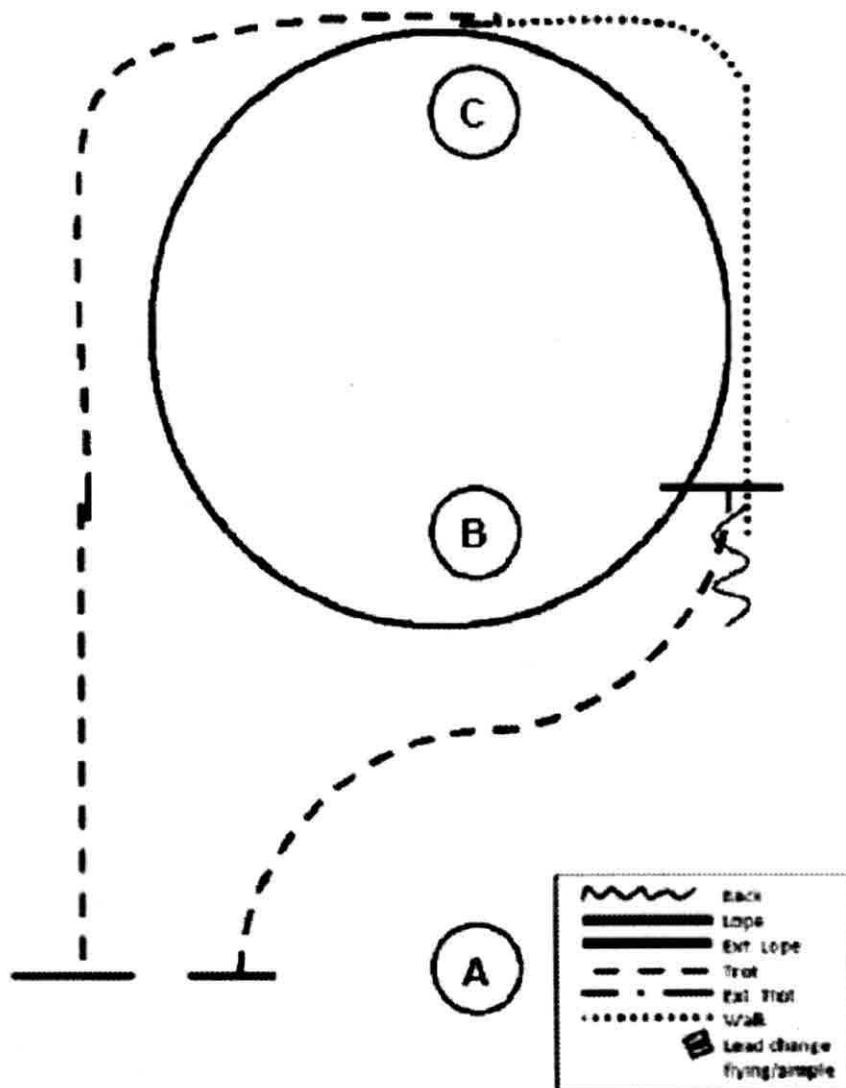

1. Bereithalten bei A, Jog, Jogslalom
2. Stop, Back up
3. Walk, Angaloppieren links
4. Lopevolte, ÜG Jog
5. Jog, Stop



# Caldern C-Turnier

26.-27.08.2017

## Trail LK 1

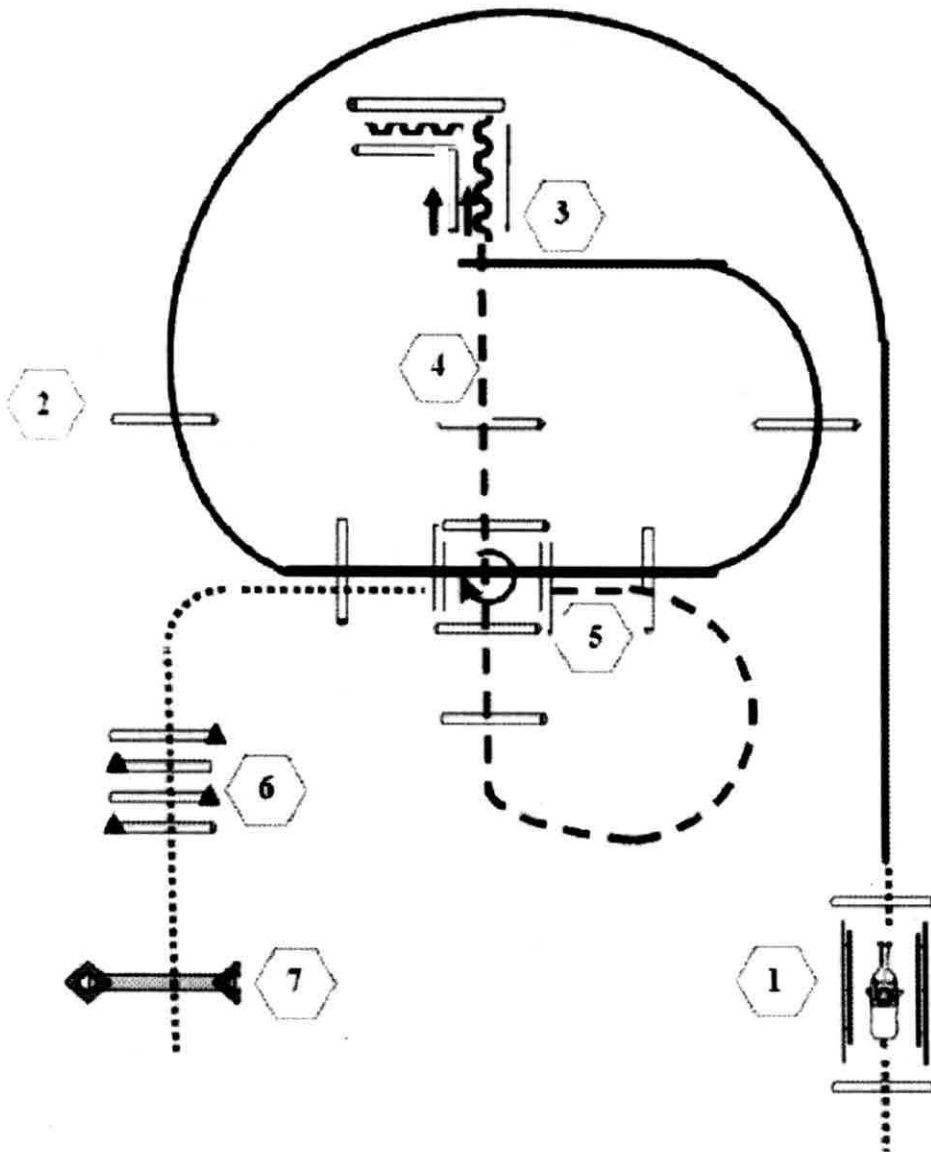

1. Brücke
2. Lope Over
3. Sidepass rechts, Backup
4. Jog Over
5. Jog in, 360° Drehung rechts, Walk Out
6. Walk Over
7. Toe

- |  |          |
|--|----------|
|  | Back Up  |
|  | Walk     |
|  | Jog      |
|  | Lope     |
|  | Wechsel  |
|  | Erhöhung |



# Caldern C-Turnier

26.-27.08.2017

## Trail LK 2

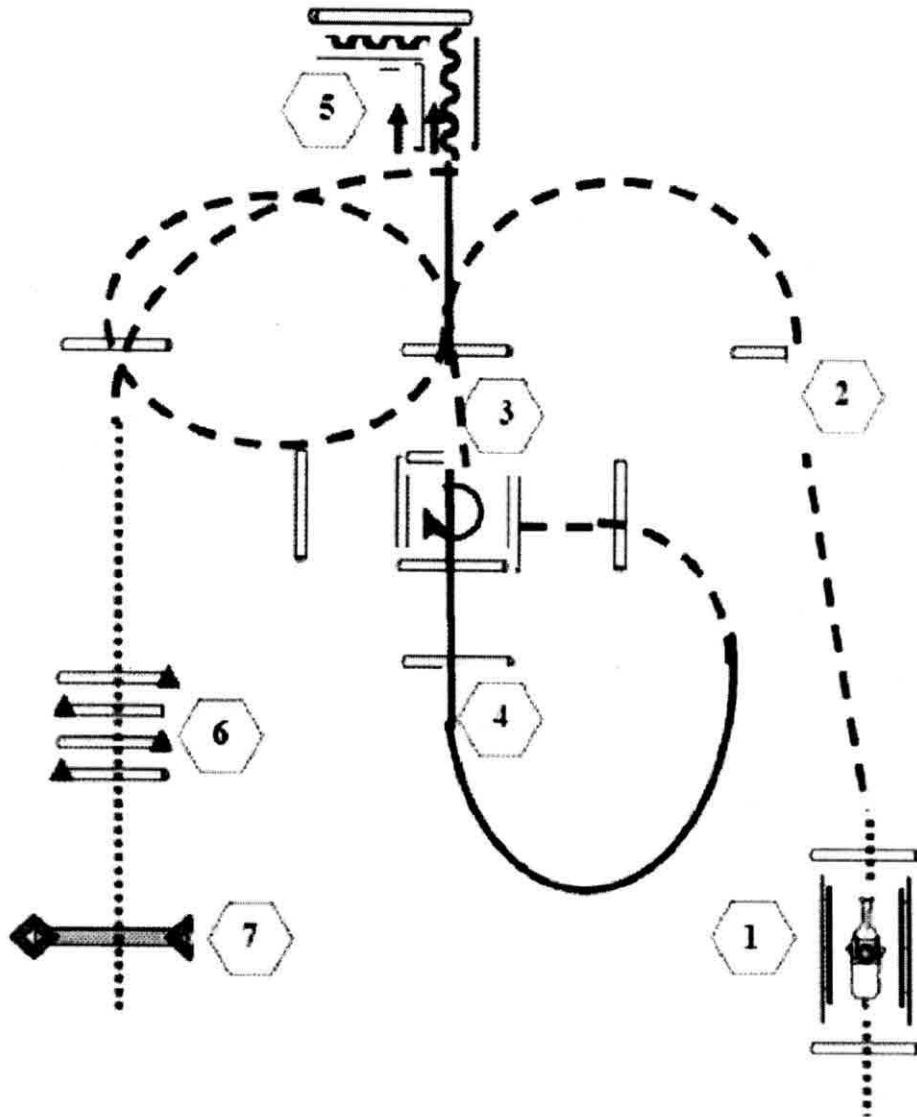

- 1. Brücke
- 2. Jog Over
- 3. Jog In, 270° Drehung rechts, Jog Out
- 4. Lope Over
- 5. Sidepass rechts, Back Up
- 6. Jog Over, Walk Over
- 7. Tor

	Back Up
	Walk
	Jog
	Lope
	Wechsel
	Erhöhung



## Trail LK 3 A/B

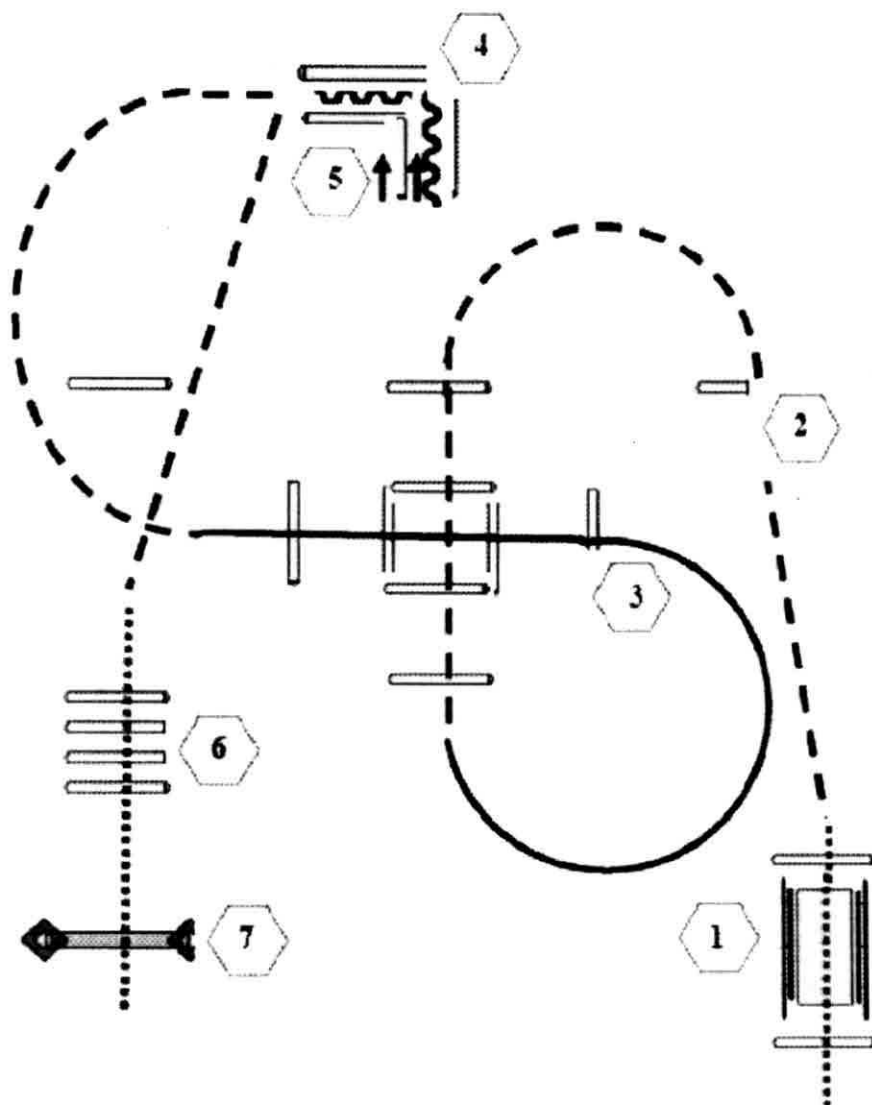

1. Brücke	Back Up
2. Jog Over	Walk
3. Lope Over	Jog
4. Back Up	Lope
5. Sidepass rechts	Wechsel
6. Walk Over	Erhöhung
7. Tor	



# Caldern C-Turnier

26.-27.08.2017

## Trail LK 4

---

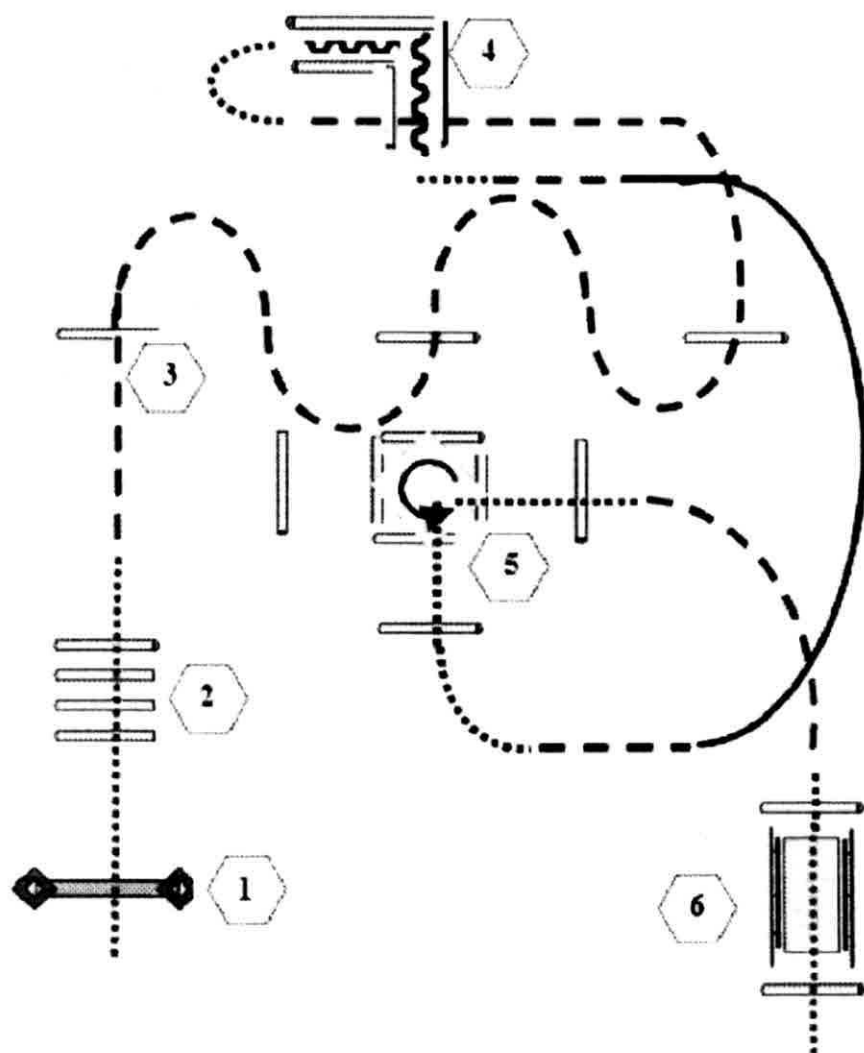

1. Tor
2. Walk Over
3. Jog Over
4. Back Up
5. Walk In, 270° Drehung links, Walk Out
6. Brücke

	Back Up
	Walk
	Jog
	Lope
	Wechsel
	Erhöhung

## Trail LK 4/5 B + 5A

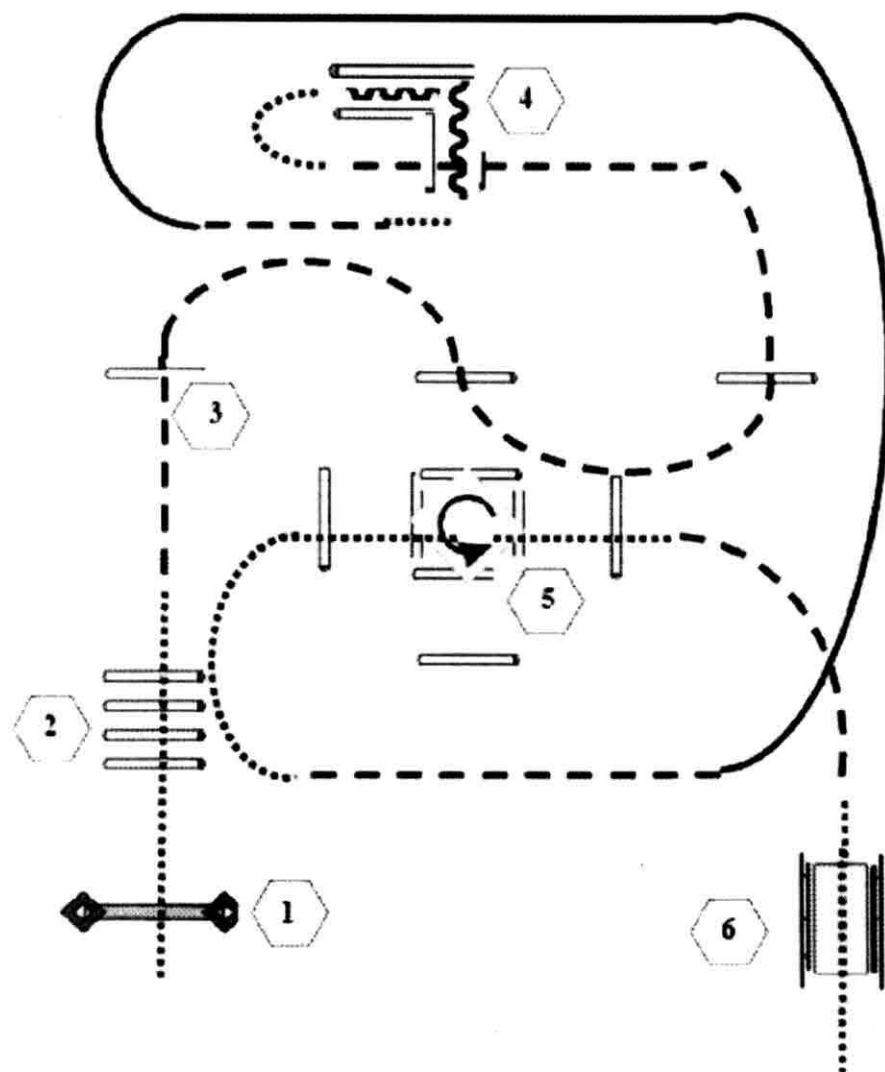

1. Tor
2. Walk Over
3. Jog Over
4. Back Up
5. Walk In, 360° Drehung links, Walk Out
6. Brücke

	Back Up
	Walk
	Jog
	Lope
	Wechsel
	Erhöhung

## Walk Trot Trail

### Walk Trot Trail (Nr.2)

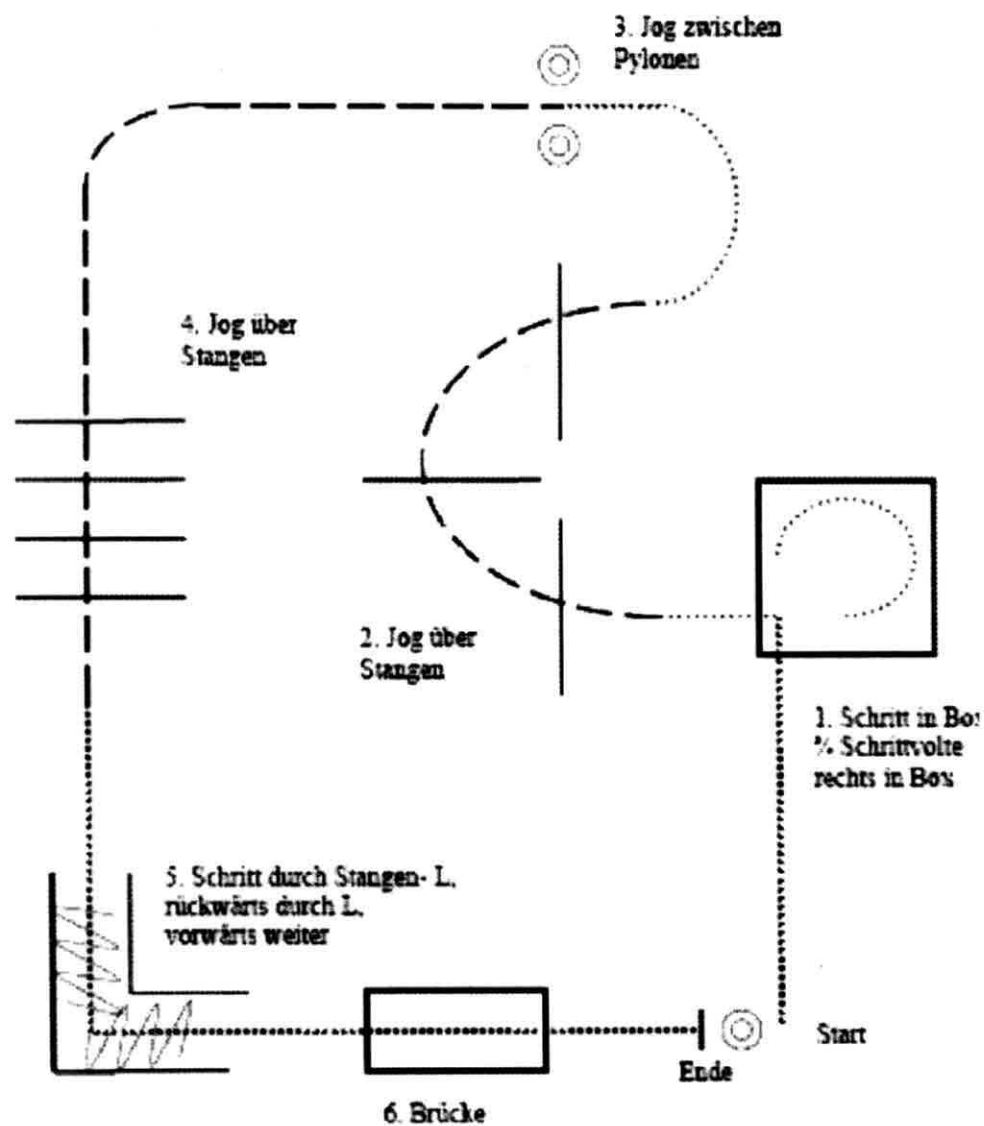

Walk Trot Horsemanship

**Walk Trot Western Horsemanship (Nr.4)**

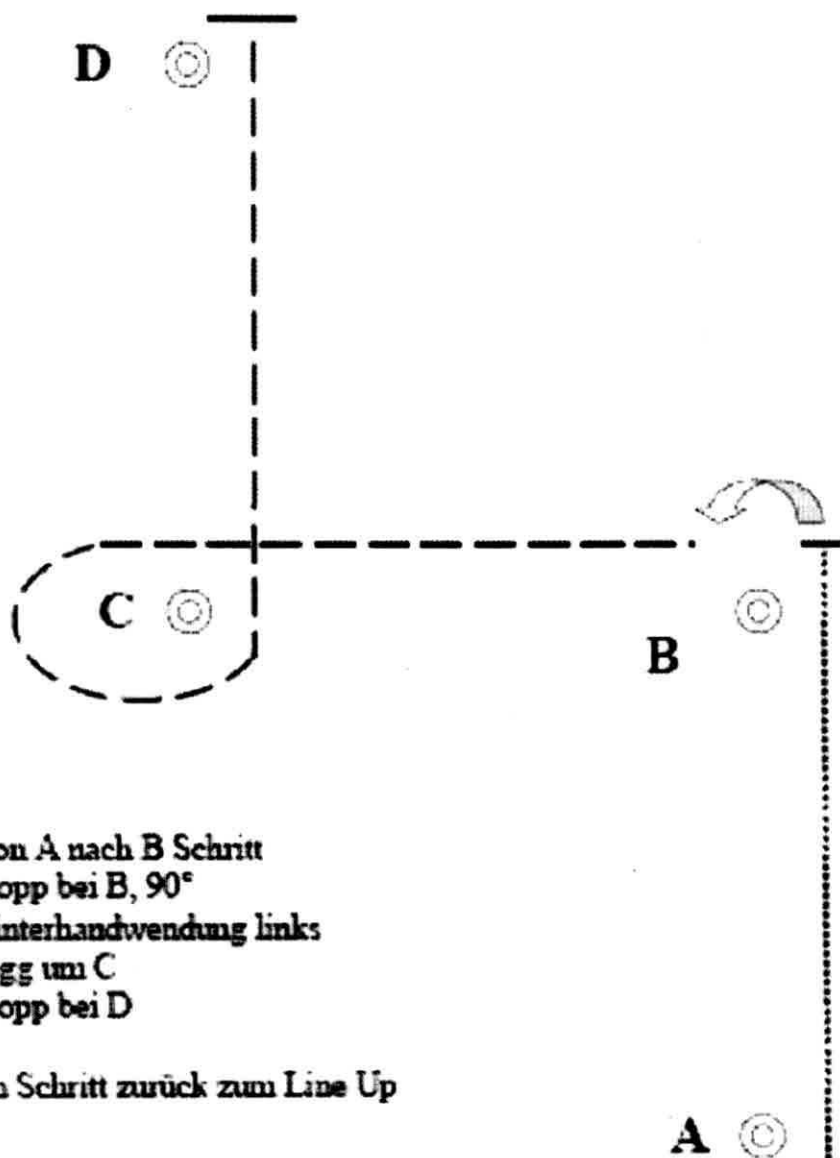

Von A nach B Schritt  
Stopp bei B, 90°  
Hinterhandwendung links  
Jogg um C  
Stopp bei D

Im Schritt zurück zum Line Up



# Trail Cup

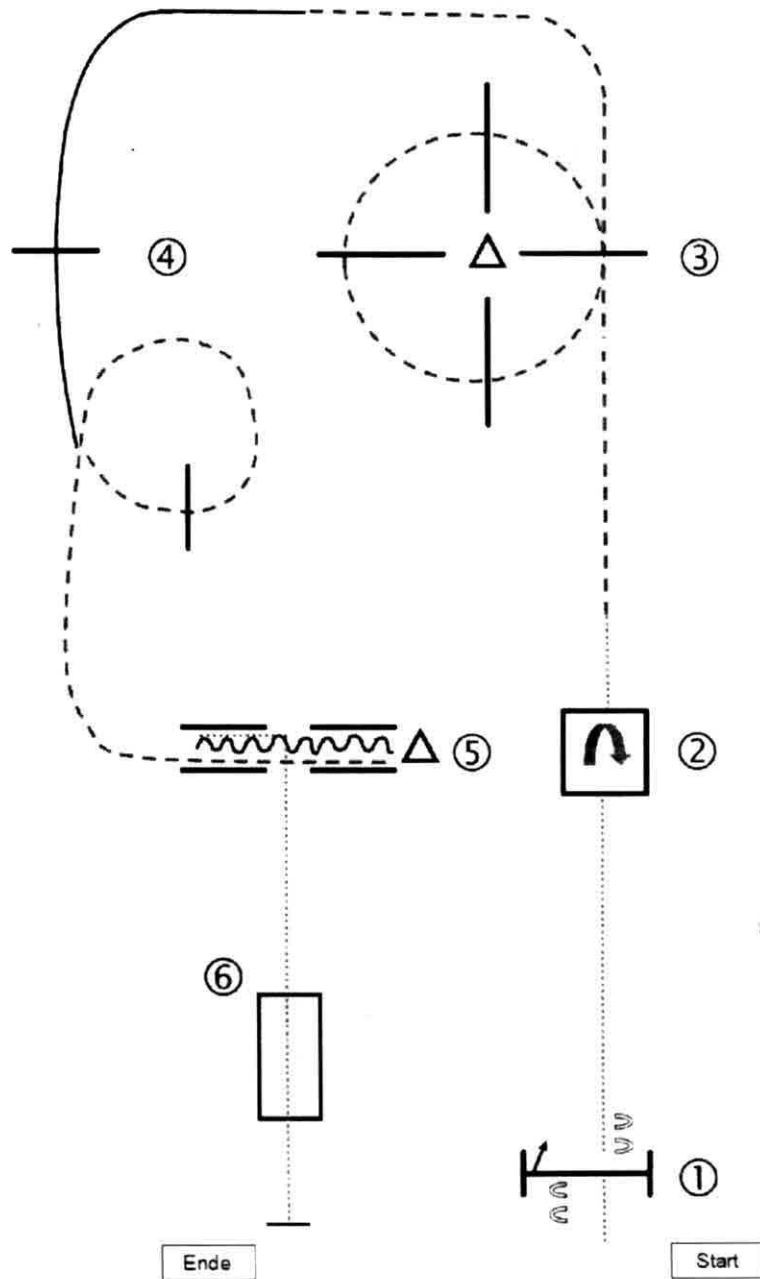

1. Seiltor (rechts öffnen)
2. Schritt in die Box, 360°Drehung nach rechts, im Schritt aus der Box
3. Antraben über Stangenzirkel (5 Stangen)
4. Angaloppieren, Galopp über die Stange, durchparieren zum Trab, Trabvolte, Trab über Stange
5. Trab in Stangengasse, Stop, rückwärtsrichten, im Schritt aus Stangengasse
6. Brücke, Stop

- ..... Schritt / Walk
- - - - - Trab / Jog
- Galopp / Lope
- ~~~~~ Rückwärtsrichten/  
Backup